



TR-600XL-4

60 Ton Capacity (54.4 Metric Tons)

HYDRAULIC ROUGH TERRAIN CRANE

DIMENSIONS

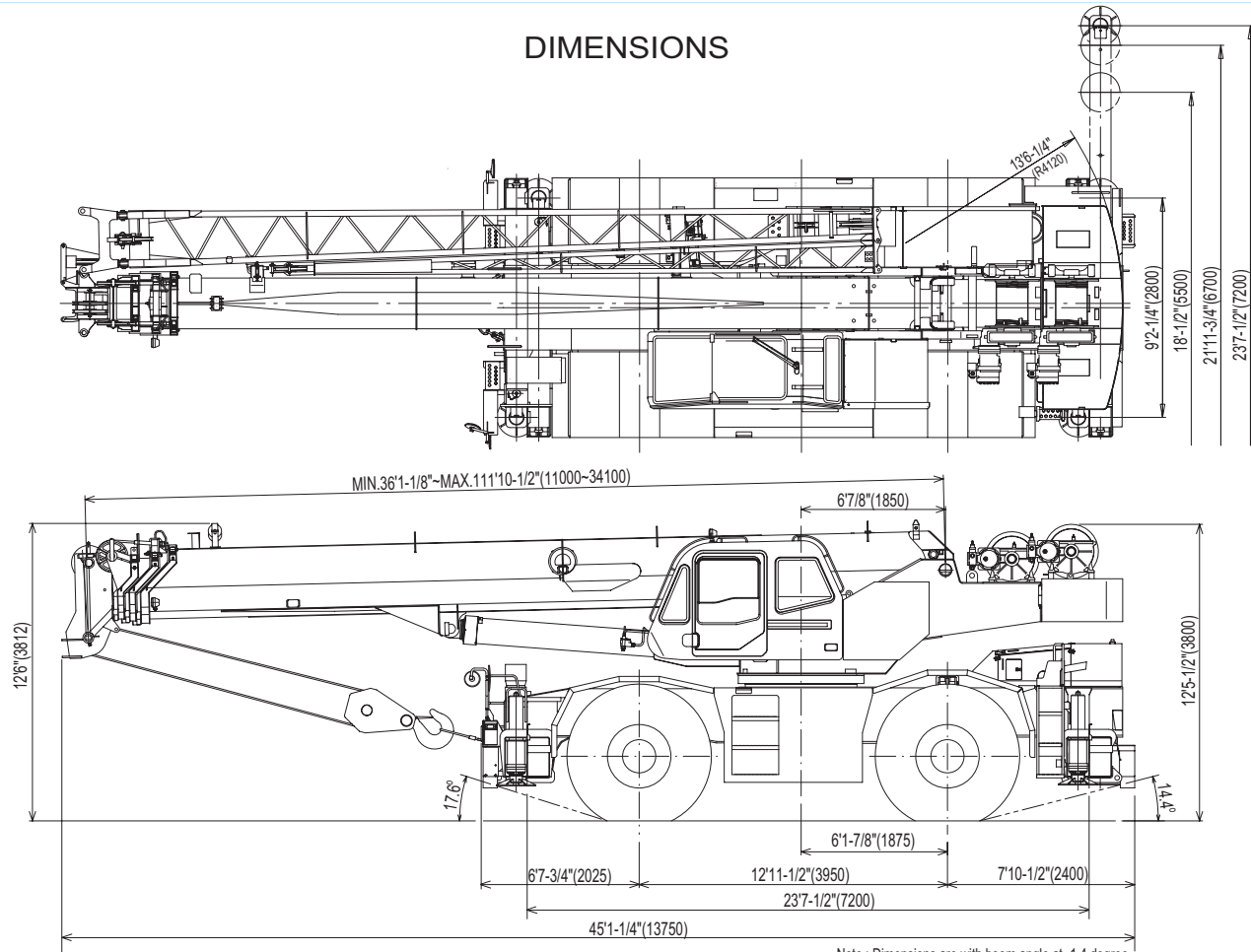

Note : Dimensions are with boom angle at -1.4 degree.

GENERAL DIMENSIONS (29.5 X 25 Tires)

	Feet	Meters
Turning radius		
4 wheel steer	21'11-3/4"	6.7
2 wheel steer	39'1/2"	11.9

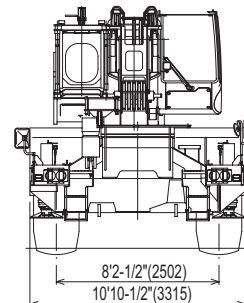

Specifications are subject to change without notice

SUPERSTRUCTURE SPECIFICATIONS

BOOM

Four section full power synchronized telescoping boom, 36' 1-1/8"~111 10-1/2" (11.0m~34.1m), of round hexagonal box construction with five sheaves, 15" (0.38m) root diameter, at boom head. The synchronization system consists of two telescope cylinders, an extension cable and retraction cable. Hydraulic cylinder fitted with holding valve. Two easily removable wire rope guards, rope dead end provided on both sides of boom head. Boom telescope sections are supported by wear pads both vertically and horizontally.

Extension speed 75' 9-3/8" in 95 seconds.

BOOM ELEVATION - By a double acting hydraulic cylinder with holding valve. Elevation -0.4°~80.5°, combination controls for hand or foot operation. Boom angle indicator. Automatic speed reduction and soft stop function. Elevation speed -0.4°~80.5° in 75 seconds.

JIB - Two stage bi-fold lattice type with 3.5°, 25° or 45° offset (tilt type). Single sheave, 15-5/8" (0.396m) root diameter, at the head of both jib sections. Stored alongside base boom section. Jib length is 32.5' (9.9m) or 58.1' (17.7m). Assistant cylinders for mounting and stowing are controlled at right side of superstructure. Self stowing jib mounting pins.

AUXILIARY LIFTING SHEAVE (SINGLE TOP)

Single sheave, 15-5/8" (0.396m) root diameter. Mounted to main boom head for single line work (stowable).

ANTI-TWO BLOCK - Pendant type over-winding cut out device with audio-visual (FAILURE lamp/BUZZER) warning system.

SWING

Hydraulic axial piston motor driven through planetary swing speed reducer. Continuous 360° full circle swing on ball bearing turntable at 2.5rpm. Equipped with manually locked/released swing brake. A 360° positive swing lock for pick and carry and travel modes, manually engaged in cab. Twin swing System: Free swing or lock swing controlled by selector switch on front console.

HOIST

MAIN HOIST - Variable speed type with grooved drum driven by hydraulic axial piston motor through winch speed reducer. Power load lowering and raising. Equipped with automatic brake (neutral brake) and counterbalance valve. Controlled independently of main hoist. Equipped with cable follower and drum rotation indicator.

DRUM - Grooved 15-3/4" (0.40m) root diameter x 22-3/4" (0.578m) wide. Wire rope: 797' of 3/4" diameter rope (243m of 19mm). Drum capacity: 1,096' (334m) 7 layers. Maximum line pull (available): 18,200lbs. (8,260kg). Maximum line speed: 585FPM (178m/min).

AUXILIARY HOIST - Variable speed type with grooved drum driven by hydraulic axial piston motor through winch speed reducer. Power load lowering and raising. Equipped with automatic brake (neutral brake) and counterbalance valve. Controlled independently of main hoist. Equipped with cable follower and drum rotation indicator.

DRUM - Grooved 15-3/4" (0.40m) root diameter x 22-3/4" (0.578m) wide. Wire rope: 436' of 3/4" diameter rope (133m of 19mm). Drum capacity: 1,096' (334m) 7 layers. Maximum line pull (available): 18,200lbs. (8,260kg). Maximum line speed: 585FPM (178m/min).

WIRE ROPE - Warrington seal wire, extra improved plow steel, preformed, independent wire rope core, right regular lay. 3/4" (19 mm) 6X37 class

HOOK BLOCKS

60 ton (54.4 metric ton) - 5 sheaves with swivel hook and safety latch, for 3/4" (19mm) wire rope.

6.2 ton (5.6 metric ton) - Weighted hook with swivel and safety latch, for 3/4" (19mm) wire rope.

HYDRAULIC SYSTEM

PUMPS - Two variable piston pumps for crane functions. Tandem gear pump for steering, swing and optional equipment. Powered by carrier engine. Pump disconnect for crane is engaged/ disengaged by rotary switch from operator's cab.

CONTROL VALVES - Multiple valves actuated by pilot pressure with integral pressure relief valves.

RESERVOIR - 195 gallon (740 lit.) capacity. External sight level gauge.

FILTRATION - 26 micron return filter, full flow with bypass protection, located inside of hydraulic reservoir. Accessible for easy replacement.

OIL COOLER - Air cooled fan type.

CAB AND CONTROLS

Both crane and drive operations can be performed from one cab mounted on rotating superstructure.

Left side, 1 man type, steel construction with sliding door access and tinted safety glass windows opening at side. Door window is powered control. Windshield glass and roof window glass window are shatter-resistant. Tilt-telescoping steering wheel. Adjustable control lever stands for swing, boom hoist, boom telescoping, auxiliary hoist and main hoist. Control lever stands can change neutral positions and tilt for easy access into cab. 3 way adjustable operator's seat with high back, headrest and armrest. Engine throttle knob. Foot operated controls: boom hoist, boom telescoping, service brake and engine throttle. Hot water cab heater and air conditioning (OPTIONAL).

Dash-mounted engine start/stop, monitor lamps, cigarette lighter ashtray, drive selector switch, parking brake switch, steering mode select switch, power window switch, pump engaged/ disengaged switch, swing brake switch, telescoping/auxiliary winch select switch, outrigger controls, main winch/auxiliary winch selector switch, swing stop cancel switch, slow elevation stop cancel switch and free swing / lock swing selector switch.

Instruments - Torque converter oil temperature, engine water temperature, air pressure, fuel, speedometer, tachometer and hour meter. Hydraulic oil pressure is monitored and displayed on the AML-L display panel.

Tadano electronic LOAD MOMENT INDICATOR system (AML-L) including:

- Control lever lockout function with audible and visual pre-warning.
- Boom position indicator
- Outrigger state indicator
- Boom angle / boom length / jib offset angle / load radius / rated lifting capacities / actual loads read out
- Ratio of actual load moment to rated load moment indication
- Automatic Speed Reduction and Soft Stop function on boom elevation and swing (swing range restricted only)
- Working condition register switch
- Load radius / boom angle / tip height / swing range preset function
- External warning lamp

CARRIER SPECIFICATIONS

TYPE - Rear engine, left hand steering, driving axle 2-way selected type by manual switch, 4x2 front drive, 4x4 front and rear drive.

FRAME - High tensile steel, all welded mono-box construction.

TRANSMISSION - Electronically controlled full automatic transmission. Torque converter driving full powershift with driving axle selector. 6 forward and 2 reverse speeds, constant mesh.

- 3 speeds - high range - 2 wheel drive; 4 wheel drive
- 3 speeds - low range - 4 wheel drive

TRAVEL SPEED - 25 mph (40 km/h)

AXLE - Front: Full floating type, steering and driving axle with planetary reduction. Rear: Full floating type, steering and driving axle with planetary reduction and non-spin rear differential.

STEERING- Hydraulic power steering controlled by steering wheel. Four steering modes available: 2 wheel front, 2 wheel rear, 4 wheel coordinated and 4 wheel crab .

TADANO AML-L monitors outrigger extended length and automatically programs the corresponding "RATED LIFTING CAPACITIES" table.

Operator's right hand console includes transmission gear selector and sight level bubble. Upper console includes working light switch, roof washer and wiper switch, oil cooler switch, emergency outrigger set up key switch, drum indicator switch, jib equipped/removed select switch, boom emergency telescoping switch (2nd and 3rd-top) and air conditioning control switch. Swing lock lever.

NOTE: Each crane motion speed is based on unladen conditions.

SUSPENSION - Front: Rigid mounted to frame. Rear: Pivot mounted with hydraulic lockout device.

BRAKE SYSTEMS - Service: Air over hydraulic disc brakes on all 4 wheels. Parking/Emergency: Spring applied-air released brake acting on input shaft of front axle. Auxiliary: Electro-pneumatic operated exhaust brake.

TIRES - 29.5-25 22PR(OR)

OUTRIGGERS - Four hydraulic, beam and jack outriggers. Vertical jack cylinders equipped with integral holding valve. Each outrigger beam and jack is controlled independently from cab. Beams extend to 23' 7-1/2" (7.2 m) center-line and retract to within 10' 10-1/2" (3.315 m) overall width with floats. Outrigger jack floats are attached thus eliminating the need of manually attaching and detaching them. Controls and sight bubble located in superstructure cab. Four outrigger extension lengths are provided with corresponding "RATED LIFTING CAPACITIES" for crane duty in confined areas.

- Min. Extension 9' 2-1/4" center to center
- Mid. Extension 18' 1/2" center to center
- Mid. Extension 21' 11-3/4" center to center
- Max. Extension 23' 7-1/2" center to center

Float size(Diameter) 1' 7-11/16" (0.5m)

ENGINE

Model	Mitsubishi 6D16-TLEE
Type	Direct injection diesel
No. of cylinders	6
Combustion	4 cycle, turbo charged and after cooled
BoreXStroke, in.(mm)	4.646 X 4.528 (118X115)
Displacement, cu. in (liters)	460 (7.545)
Air inlet heater	24 volt preheat
Air cleaner	Dry type, replaceable element
Oil filter	Full flow with replaceable element
Fuel filter	Full flow with replaceable element
Fuel tank, gal.(liters)	79.2 (300), right side of carrier
Cooling	Liquid pressurized, recirculating by-pass

Radiator	Fin and tube core, thermostat controlled
Fan, in.(mm)	Suction type, 6-blade, 23.6 (600) dia.
Starting	24 volt
Charging	24 volt system, negative ground
Battery	2-120 amp. Hour
Compressor, air, CFM(l /min)	9.2 CFM (260) at 2,800rpm
Horsepower (kW)	Gross 223 (166) at 2,700rpm
Torque, Max. ft-lb (kgm)	521 (72) at 1,300rpm
Capacity, gal.(liters)	
Cooling water	3.4 (13)
Lubrication	3.7 ~ 4.2 (14 ~ 16)
Fuel	79.2 (300)

STANDARD EQUIPMENT

- Four section full power partially synchronized boom 36.1'~111.9' (11.0 m~34.1 m)
- 32.5'~58.1' (9.9 m~17.7 m) bi-fold lattice jib (tilt type) with 3.5°, 25° or 45° pinned offsets and self storing pins.
- Auxiliary lifting sheave (single top) stowable
- Variable speed main hoist with grooved drum, cable follower and 623' of 3/4" cable.
- Variable speed auxiliary hoist with grooved drum, cable follower and 367' of 3/4" cable.
- Drum rotation indicator (thumper type) main and auxiliary hoist
- Anti-Two block device (overwind cutout)
- Boom angle indicator
- Tadano electronic load moment indicator system (AML-L)
- Outrigger extension length detector
- Electronic crane monitoring system
- Tadano twin swing system and 360° positive swing lock
- Self centering finger control levers with pilot control
- Control pedals for boom hoist and boom telescoping
- 3 way adjustable cloth seat with armrests, high back and seat belt
- Tilt-telescoping steering wheel
- Tinted safety glass and sun visor
- Front windshield wiper and washer
- Roof window wiper and washer
- Power window (cab door)
- Rear view mirrors (right and left side)
- Mirror for main and auxiliary hoists
- Cigarette lighter and ashtray
- Electric fan in cab
- Cab floor mat
- Pump disconnect in operator's cab
- Hydraulic oil cooler
- Independently controlled outriggers
- Four outrigger extension positions
- Self-storing outrigger pads
- Outrigger hose protection
- Mitsubishi 6D16-TLEE turbo charged after cooled engine (223HP) with exhaust brake
- Electronic controlled automatic transmission driven by torque converter
- 4 X 4 X 4 drive/steer
- Non-spin rear differential
- Automatic rear axle oscillation lockout system
- 29.5-25 22PR (OR) tires
- Disc brakes
- Fenders
- Air dryer
- Water separator with filter
- Engine over-run alarm
- Back-up alarm
- Low oil pressure/high water temp. warning device (visual)
- Rear steer centering light
- Air cleaner dust indicator
- Full instrumentation package
- Complete highway light package
- Flood lights and work lights
- Tool storage compartment
- Tire inflation kit
- 24 volt electric system
- 60 ton (54.4 metric ton) 5 sheave hook block
- 6.2 ton (5.6 metric ton) hook with swivel
- Towing hooks-Front and rear
- Lifting eyes
- Hook block tie down (front bumper)
- Weighted hook storage compartment

OPTIONAL EQUIPMENT

- Hot water cab heater and air conditioner
- Propane heater (less tank)

HOISTING PERFORMANCE

LINE SPEEDS AND PULLS

Layer	Speed	Main or auxiliary hoist - 15'-3/4" (0.4m) drum					
		Line speeds ²		Line pulls			
		F.P.M	m/min	Available ¹		Permissible ⁴	
				Lbs.	kgf	Lbs.	kgf
1st	High	378	115	18,200	8,260	15,200	6,880
2nd	High	413	126	16,700	7,570	13,900	6,310
3rd	High	448	136	15,400	6,990	12,800	5,820
4th	High	482	147	14,300	6,490	11,900	5,410
5th	High	502	157	13,400	6,060	11,100	5,050
6th ³	High	551	168	12,500	5,680	10,400	4,730
7th ³	High	585	178	11,800	5,350	9,800	4,460

¹ Developed by machinery with each layer of wire rope, but not based on rope strength or other limitation in machinery or equipment.

² Line speeds based only on hook block, not loaded.

³ Sixth layer and seventh layer of wire rope are not recommended for hoisting operations.

⁴ Permissible line pull may be affected by wire rope strength.

DRUM WIRE ROPE CAPACITIES

Wire rope layer	Main and auxiliary drum grooved lagging			
	3/4" (19mm) wire rope			
	Rope per layer		Total wire rope	
	Feet	Meters	Feet	Meters
1	123.0	37.5	123.0	37.5
2	134.2	40.9	257.2	78.4
3	145.3	44.3	402.6	122.7
4	156.5	47.7	559.1	170.4
5	167.7	51.1	726.7	221.5
6	178.8	54.5	905.5	276.0
7	190.0	57.9	1,095.5	333.9

DRUM DIMENSIONS

	Inch	mm
Root diameter	15-3/4"	400
Length	22-3/4"	578
Flange diameter	27-3/8"	695

TR-600XL WORKING RANGE CHART

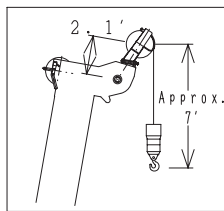
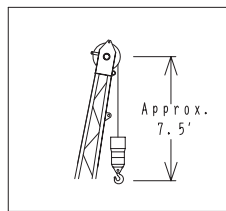
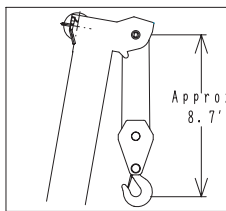
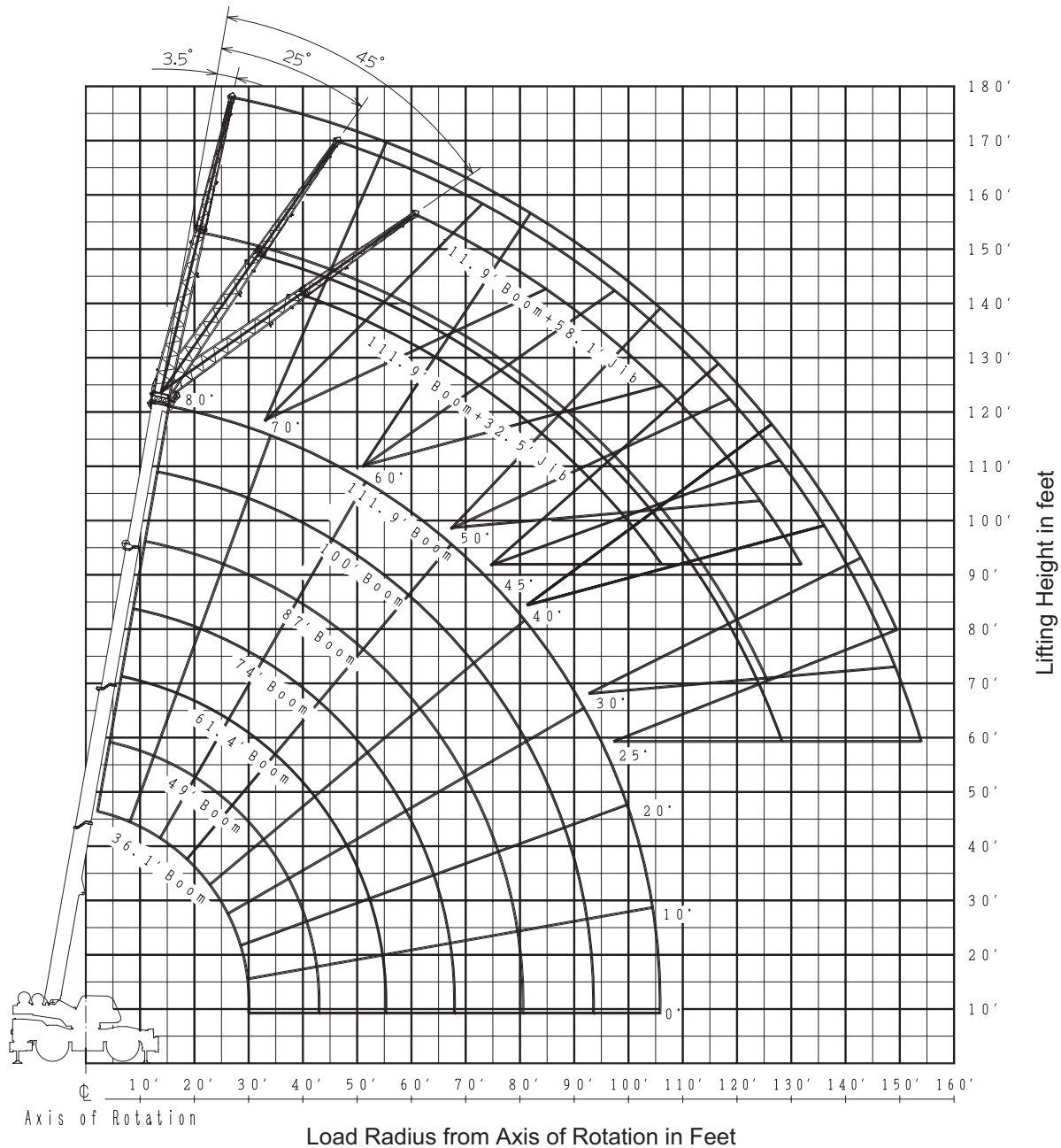

NOTE : 1. Boom and jib geometry shown are for unloaded condition and machine standing level on firm supporting surface. Boom deflection and subsequent radius and boom angle change must be accounted for when applying load to hook.

Boom Length in Feet

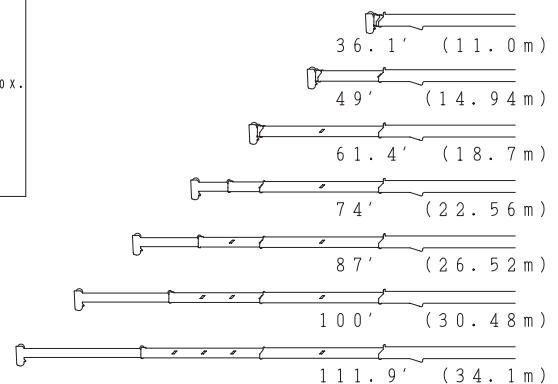

WEIGHT REDUCTIONS FOR AUXILIARY LOAD HANDLING EQUIPMENT

Load Handling Equipment										
Main Hook Block(See Hook Block for actual weight)						 (lbs.)			
Aux.Hook(See Hook for actual weight)							330 (lbs.)			
Lifting from Main Boom with										
#1	Base and/or Top Jib stowed on base boom							0 (lbs.)		
	Single Top stowed on top boom							0 (lbs.)		
	Single Top erected but not used							0 (lbs.)		Fig.1
	32.5'(9.9m)Base Jib erected but not used							(lbs.)		Fig.2
	Boom Length		36.1'	49'	61.4'	74'	87'	100'	111.9'	
		14,100	10,600	8,500	6,300	6,300	5,700	4,900		
32.5'(9.9m)Base Jib erected but not used +Aux.Hook on Top jib							(lbs.)		Fig.3	
Boom Length		36.1'	49'	61.4'	74'	87'	100'	111.9'		
		14,900	11,800	9,700	7,400	7,400	6,800	5,800		
58.1'(17.7m)Base and Top Jib erected but not used							(lbs.)		Fig.4	
Boom Length		36.1'	49'	61.4'	74'	87'	100'	111.9'		
		15,300	11,800	9,600	7,300	7,300	6,700	5,800		
58.1'(17.7m)Base and Top Jib erected but not used +Aux.Hook on Top jib							(lbs.)		Fig.5	
Boom Length		36.1'	49'	61.4'	74'	87'	100'	111.9'		
		17,800	14,200	12,200	9,600	9,600	8,700	7,500		
Lifting from 32.5'(9.9m)Base Jib with										
25.6'Top Jib erected but not used							Prohibited			
25.6'Top Jib stowed on 32.5'Base Jib							Prohibited			

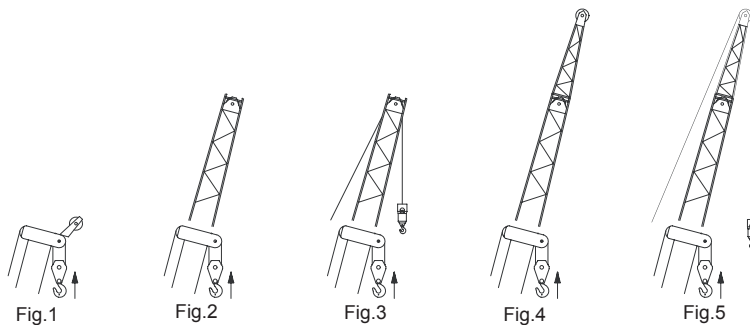

- Note
- * Capacity deductions are for TADANO supplied equipment only.
 - * When lifting from Jib, deduct total weight of all load handling devices reeved on Main Boom nose directly from Jib capacity. (#2)
- #1. Correct state of Jib, equipped or removed, should be inputted into the LOAD MOMENT INDICATOR(AML-L) by Jib state key switch.
- #2. The winch which is lifting load should be defined in the LOAD MOMENT INDICATOR(AML-L) by main winch/auxiliary winch selector switch.

TR-600XL-4 RATED LIFTING CAPACITIES (IN POUNDS)

ON OUTRIGGERS MID EXTENDED 18' 1/2" (5.5m) SPREAD														
360° ROTATION														
A	36.1'		49'		61.4'		74'		87'		100'		111.9'	
B	C	(11.0m)	C	(14.94m)	C	(18.7m)	C	(22.56m)	C	(26.52m)	C	(30.48m)	C	(34.1m)
10	67.0	120,000	73.6	90,600	77.2	68,300	79.4	40,700						
12	63.2	107,000	71.2	90,600	75.3	68,300	77.9	40,700	80.2	40,700				
15	57.6	88,200	67.5	90,600	72.6	66,200	75.6	40,700	78.2	40,700	80.1	37,200		
20	47.2	55,400	60.8	54,500	67.5	54,000	71.7	40,700	75.0	40,700	77.5	37,200	78.8	27,800
25	34.0	36,100	53.5	35,500	62.2	35,300	67.7	37,000	71.6	35,300	74.6	32,300	76.4	27,800
30	7.8	24,800	45.5	25,100	56.7	25,000	63.3	26,600	68.0	27,600	71.5	27,600	73.8	24,400
35			35.7	18,600	50.8	18,500	58.7	20,000	64.3	20,900	68.4	21,800	71.2	21,600
40			22.6	14,200	43.9	14,100	53.9	15,500	60.4	16,300	65.1	17,100	68.3	17,500
45					36.3	10,700	48.8	12,100	56.5	12,900	61.8	13,600	65.4	14,000
50					26.6	8,100	43.1	9,400	52.2	10,200	58.4	10,900	62.5	11,300
55					8.7	6,100	36.8	7,300	47.7	8,100	54.8	8,800	59.3	9,100
60							29.0	5,700	42.8	6,400	51.0	7,000	56.1	7,400
65							18.5	4,300	37.3	5,000	46.9	5,600	52.8	6,000
70									31.0	3,900	42.7	4,500	49.3	4,800
75									23.3	2,900	38.0	3,500	45.6	3,800
80									10.5	2,100	32.7	2,600	41.7	3,000
85											26.6	1,900	37.4	2,300
90											18.6	1,300	32.6	1,600
95													27.1	1,100
D	0°												26°	

LIFTING CAPACITIES AT ZERO DEGREE BOOM ANGLE ON OUTRIGGERS														
MID EXTENDED 18' 1/2" (5.5m) SPREAD 360° ROTATION														
A	36.1'		49'		61.4'		74'		87'		100'			
C	B	(11.0m)	B	(14.94m)	B	(18.7m)	B	(22.56m)	B	(26.52m)	B	(30.48m)		
0	30.0	24,800	42.9	12,100	55.3	6,100	67.9	3,900	80.9	2,000	93.9	1,100		

A : Boom length in feet C : Loaded boom angle (deg.)
 B : Load radius in feet D : Minimum boom angle (deg.) for indicated length (no load)

ON OUTRIGGERS FULLY RETRACTED 9' 2-1/4" (2.8m) SPREAD														
360° ROTATION														
A	36.1'		49'		61.4'		74'		87'		100'		111.9'	
B	C	(11.0m)	C	(14.94m)	C	(18.7m)	C	(22.56m)	C	(26.52m)	C	(30.48m)	C	(34.1m)
10	66.8	66,000	73.5	66,000	77.1	65,000	79.6	40,700						
12	63.1	48,900	70.9	48,900	75.1	48,300	78.1	40,700	80.3	40,700				
15	57.4	33,600	67.1	33,500	72.2	33,100	75.7	35,200	78.3	35,400	80.0	23,300		
20	47.0	20,400	60.5	20,200	67.1	20,000	71.5	21,600	74.7	22,600	77.2	23,300	78.9	16,500
25	33.8	13,300	53.3	13,200	61.9	13,000	67.2	14,400	71.1	15,300	74.1	16,000	76.5	16,500
30	7.7	8,700	45.3	8,700	56.5	8,600	62.8	10,000	67.5	10,800	71.0	11,500	73.7	11,900
35			35.7	5,600	50.5	5,500	58.2	6,800	63.7	7,600	67.8	8,200	70.8	8,600
40			22.5	3,300	43.8	3,200	53.4	4,400	59.9	5,200	64.5	5,800	67.9	6,200
45					36.2	1,400	48.2	2,700	55.8	3,400	61.2	4,000	65.0	4,400
50							42.6	1,300	51.6	2,000	57.7	2,600	62.0	3,000
55											54.1	1,500	58.9	1,800
D	0°				31°		38°		46°		52°		56°	

LIFTING CAPACITIES AT ZERO DEGREE BOOM ANGLE ON OUTRIGGERS														
FULLY RETRACTED 9' 2-1/4" (2.8m) SPREAD 360° ROTATION														
A	36.1'		49'											
C	B	(11.0m)	B	(14.94m)										
0	30.0	8,700	42.9	2,900										

A : Boom length in feet C : Loaded boom angle (deg.)
 B : Load radius in feet D : Minimum boom angle (deg.) for indicated length (no load)

TR-600XL-4 RATED LIFTING CAPACITIES (IN POUNDS)

ON OUTRIGGERS FULLY EXTENDED 23' 7-1/2" (7.2m) SPREAD 360° ROTATION												
C	111.9' (34.1m) Boom + 32.5' (9.9m) Jib						111.9' (34.1m) Boom + 58.1' (17.7m) Jib					
	3.5° offset		25° offset		45° offset		3.5° offset		25° offset		45° offset	
	R	W	R	W	R	W	R	W	R	W	R	W
80°	25.8	12,300	36.8	11,000	44.5	8,400	33.4	7,900	53.9	6,000	67.3	4,400
75°	39.4	12,300	49.4	10,200	56.2	8,200	50.2	7,900	68.1	5,300	79.7	4,100
70°	52.3	11,800	61.2	8,700	67.0	7,300	65.3	7,200	81.2	4,800	91.1	3,900
65°	63.7	9,600	71.9	7,700	76.6	6,700	78.8	6,300	94.0	4,400	101.9	3,700
60°	74.6	8,000	82.1	6,800	86.5	6,100	91.6	5,300	105.4	3,900	111.8	3,400
55°	84.8	6,900	91.6	6,000	95.3	5,600	103.9	4,600	116.0	3,600	120.8	3,200
50°	94.1	5,600	100.2	5,200	103.5	4,900	114.6	4,000	125.2	3,300	128.7	3,000
45°	102.6	4,500	108.0	4,200	110.5	4,000	124.1	3,000	133.6	2,800	135.8	2,450
40°	110.2	3,600	115.0	3,400			132.7	2,300	140.7	2,200		
35°	117.2	2,900	121.4	2,850			140.4	1,800	147.3	1,700		
30°	123.3	2,400	126.8	2,350			147.3	1,300	152.8	1,300		
25°	128.7	2,000	131.0	2,050			153.3	1,000	157.1	1,000		

C : Loaded boom angle (deg.)
R : Load radius in feet
W : Rated lifting capacity in pounds

ON OUTRIGGERS MID EXTENDED 21' 11-3/4" (6.7m) SPREAD 360° ROTATION												
C	111.9' (34.1m) Boom + 32.5' (9.9m) Jib						111.9' (34.1m) Boom + 58.1' (17.7m) Jib					
	3.5° offset		25° offset		45° offset		3.5° offset		25° offset		45° offset	
	R	W	R	W	R	W	R	W	R	W	R	W
80°	25.8	12,300	36.8	11,000	44.5	8,400	33.4	7,900	53.9	6,000	67.3	4,400
75°	39.4	12,300	49.4	10,200	56.2	8,200	50.2	7,900	68.1	5,300	79.7	4,100
70°	52.3	11,800	61.2	8,700	67.0	7,300	65.3	7,200	81.2	4,800	91.1	3,900
65°	63.7	9,600	71.9	7,700	76.6	6,700	78.8	6,300	94.0	4,400	101.9	3,700
60°	74.2	7,400	82.1	6,500	86.5	6,100	91.4	5,100	105.4	3,900	111.8	3,400
55°	84.1	5,500	91.2	5,000	94.8	4,800	103.0	3,700	115.4	3,200	120.8	3,000
50°	93.4	4,100	99.7	3,800	102.7	3,600	113.3	2,600	124.5	2,300	128.3	2,200
45°	101.7	3,100	107.5	2,800	109.9	2,700	122.7	1,800	132.5	1,600	135.5	1,500
40°	109.7	2,300	114.5	2,100			131.8	1,200	140.2	1,000		
35°	116.7	1,700	120.9	1,600								
30°	122.8	1,200	126.2	1,200								

C : Loaded boom angle (deg.)
R : Load radius in feet
W : Rated lifting capacity in pounds

ON OUTRIGGERS MID EXTENDED 18' 1/2" (5.5m) SPREAD 360° ROTATION												
C	111.9' (34.1m) Boom + 32.5' (9.9m) Jib						111.9' (34.1m) Boom + 58.1' (17.7m) Jib					
	3.5° offset		25° offset		45° offset		3.5° offset		25° offset		45° offset	
	R	W	R	W	R	W	R	W	R	W	R	W
80°	25.8	12,300	36.8	11,000	44.5	8,400	33.4	7,900	53.9	6,000	67.3	4,400
75°	39.4	12,300	49.4	10,200	56.2	8,200	50.2	7,900	68.1	5,300	79.7	4,100
70°	51.6	10,500	61.2	8,700	67.0	7,300	65.3	7,200	81.2	4,800	91.1	3,900
65°	62.7	7,300	71.1	6,200	76.3	5,800	78.3	5,400	93.8	4,200	101.9	3,700
60°	73.2	5,100	81.1	4,400	85.6	4,200	89.9	3,600	104.5	2,900	111.4	2,700
55°	83.2	3,600	90.3	3,200	94.3	3,000	101.3	2,300	114.2	1,800	120.0	1,800
50°	92.7	2,400	98.8	2,200	102.3	2,100	112.0	1,300	123.4	1,100	127.8	1,100
45°	101.2	1,500	106.8	1,400	109.3	1,400						

C : Loaded boom angle (deg.)
R : Load radius in feet
W : Rated lifting capacity in pounds

Boom length in feet

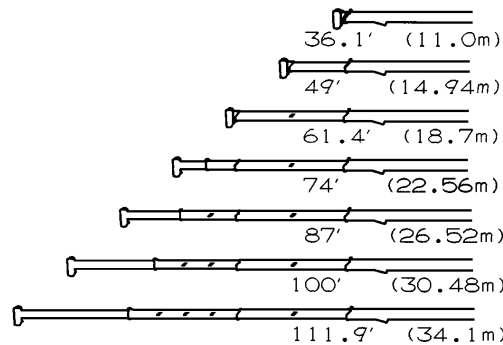

NOTE: Load radiuses for jib operation are given for reference with the boom fully extended to 111.9' (34.1m).

Standard number of parts of line for outrigger operation should be according to the following table.

Boom Length in Feet (meters)	36.1' (11)	36.1' to 49' (11 to 14.94)	49' to 61.4' (14.94 to 18.7)	Single top Jib
Number of parts of line	10	6	4	1

The lifting capacity data stored in the LOAD MOMENT INDICATOR (AML-L) is based on the standard number of parts of line listed in the chart. Maximum lifting capacity is restricted by the number of parts of line of LOAD MOMENT INDICATOR (AML-L).

WARNING AND OPERATING INSTRUCTIONS FOR LIFTING CAPACITIES

GENERAL

1. RATED LIFTING CAPACITIES apply only to the machine as originally manufactured and normally equipped by TADANO LTD. Modifications to the machine or use of optional equipment other than that specified can result in a reduction of capacity.
2. Construction equipment can be hazardous if improperly operated or maintained. Operation and maintenance of this machine must be in compliance with information in the operation, safety and maintenance manual supplied with machine. If these manuals are missing, order replacements through the distributor.
3. The operator and other personnel associated with this machine shall fully acquaint themselves with the latest American National Standards Institute (ANSI) safety standards for cranes.

SET UP

1. Rated lifting capacities on the chart are the maximum allowable crane capacities and are based on the machine standing level on firm supporting surface under ideal job conditions. Depending on the nature of the supporting surface, it may be necessary to have structural supports under the outrigger floats or tires to spread the loads to a larger bearing surface.
2. For outrigger operation, outriggers shall be properly extended with tires free of supporting surface before operating crane.

OPERATION

1. Rated lifting capacities have been tested to and meet minimum requirements of SAE J1063-Cantilevered Boom Crane Structures Method of Test.
2. Rated lifting capacities do not exceed 85 % of the tipping load on outriggers fully extended as determined by SAE J765-Crane Stability Test Code.
Rated lifting capacities for partially extended outriggers are determined from the formula, Rated Lifting Capacities = (Tipping Load - 0.1 x Tip Reaction) / 1.25.
3. Rated lifting capacities above bold lines in the chart are based on crane strength and those below, on its stability. They are based on actual load radius increased by boom deflection.
4. The weight of handling device such as hook blocks, slings, etc., must be considered as part of the load and must be deducted from the lifting capacities.
5. Rated lifting capacities are based on freely suspended loads and make no allowance for such factors as the effect of wind, sudden stopping of loads, supporting surface conditions, inflation of tires, operating speeds, side loads, etc. Side pull on boom or jib is extremely dangerous.
6. Rated lifting capacities do not account for wind on lifted load or boom. Rated lifting capacities and boom length shall be appropriately reduced, when wind velocity is above 20 mph (9 m/sec.).
7. Rated lifting capacities at load radius shall not be exceeded. Do not tip the crane to determine allowable loads.
8. Do not operate at boom lengths, radii, or boom angle, where no capacities are shown. Crane may overturn without any load on the hook.
9. When boom length is between values listed, refer to the rated lifting capacities of the next longer and next shorter booms for the same radius. The lesser of the two rated lifting capacities shall be used.

10. When making lifts at a load radius not shown, use the next longer radius to determine allowable capacity.
11. Load per line should not exceed 12,300 lbs. (5,600kg) for main winch and auxiliary winch.
12. Check the actual number of parts of line with LOAD MOMENT INDICATOR (AML-L) before operation. Maximum lifting capacity is restricted by the number of parts of line of LOAD MOMENT INDICATOR (AML-L). Limited capacity is as determined from the formula, Single line pull for main winch (12,300 lbs.) x number of parts of line.
13. The boom angle before loading should be greater to account for deflection. For rated lifting capacities, the loaded boom angle and the load radius is for reference only.
14. The 36.1' (11.0m) boom length capacities are based on boom fully retracted. If not fully retracted [less than 49'(14.94m) boom length], use the rated lifting capacities for the 49' (14.94m) boom length.
15. Extension or retraction of the boom with loads may be attempted within the limits of the RATED LIFTING CAPACITIES. The ability to telescope loads is limited by hydraulic pressure, boom angle, boom length, crane maintenance, etc.
16. For lifting capacity of single top, reduce the rated lifting capacities of relevant boom according to a weight reductions for auxiliary load handling equipment. Capacities of single top shall not exceed 12,300 lbs. (5,600kg) including main hook.
17. When base jib or top jib or both jib removing, jib state switch select removed.
18. When erecting and stowing jib, be sure to retain it by hand or by other means to prevent its free movement.
19. Use "ANTI-TWO BLOCK" disable switch when erecting and stowing jib and when stowing hook block. While the switch is pushed, the hoist does not stop, even when overwind condition occurs.
20. For boom length with 32.5' (9.9m) jib, rated lifting capacities are determined by loaded boom angle only in the column headed "111.9' (34.1m) boom + 32.5' (9.9m) jib".
For boom length with 58.1' (17.7 m) jib, rated lifting capacities are determined by loaded boom angle only in the column headed "111.9' (34.1m) boom + 58.1' (17.7m) jib".
For angles not shown, use the next lower loaded boom angle to determine allowable capacity.
21. When lifting a load by using jib (aux. winch) and boom (main winch) simultaneously, do the following:
 - Enter the operation status as jib operation, not as boom operation.
 - Before starting operation, make sure that mass of load is within rated lifting capacity for jib.

DEFINITIONS

1. Load Radius: Horizontal distance from a projection of the axis of rotation to supporting surface before loading to the center of the vertical hoist line or tackle with load applied.
2. Loaded Boom Angle: The angle between the boom base section and the horizontal, after lifting the rated lifting capacity at the load radius.
3. Working Area: Area measured in a circular arc about the centerline of rotation.
4. Freely Suspended Load: Load hanging free with no direct external force applied except by the hoist line.
5. Side Load: Horizontal side force applied to the lifted load either on the ground or in the air.

TR-600XL-4 RATED LIFTING CAPACITIES (IN POUNDS)

ON RUBBER															TIRE : 29.5-25 22PR					
A	Stationary												Creep							
	OVER FRONT						360° ROTATION						OVER FRONT							
	36.1'		61.4'		87'		36.1'		61.4'		87'		36.1'	61.4'	87'					
B	C	(11.0m)	C	(18.7m)	C	(26.52m)	C	(11.0m)	C	(18.7m)	C	(26.52m)	C	(11.0m)	C	(18.7m)	C	(26.52m)		
10	66.7	67,200					66.7	40,000					66.7	50,000						
12	63.0	58,600					63.0	33,200					62.9	45,600						
15	57.4	48,500	72.2	34,100			57.4	24,400	72.1	21,900			57.4	39,600	72.2	34,100				
20	47.0	34,500	67.2	30,000	74.7	20,700	46.9	14,700	67.1	13,900	74.3	15,900	47.0	30,600	67.2	30,000	74.7	20,700		
25	33.9	23,900	62.0	23,100	71.2	20,700	33.4	9,600	61.8	9,000	70.8	10,700	33.9	23,900	62.0	23,100	71.2	20,700		
30	7.7	17,100	56.6	16,600	67.6	17,600	7.8	6,100	56.4	5,700	67.3	7,300	7.7	17,100	56.6	16,200	67.6	17,600		
35			50.5	12,400	64.0	14,200			50.5	3,300	63.6	4,800			50.5	12,400	64.0	14,200		
40			44.0	9,300	60.2	11,000			43.7	1,600	59.8	3,000			44.0	9,300	60.2	11,000		
45			36.3	6,900	56.3	8,600					55.9	1,700			36.3	6,900	56.3	8,600		
50			26.4	5,000	52.1	6,700									26.4	5,000	52.1	6,700		
55			8.7	3,600	47.5	5,300									8.7	3,600	47.5	5,300		
60					42.5	4,000											42.5	4,000		
65					37.3	3,000											37.3	3,000		
70					30.9	2,200											30.9	2,200		
D					0°	20°		0°	41°	54°				0°			20°			

LIFTING CAPACITIES AT ZERO DEGREE BOOM ANGLE ON RUBBER OPERATION																		
A	Stationary												Creep					
	OVER FRONT						360° ROTATION						OVER FRONT					
	36.1'		61.4'				36.1'				61.4'		36.1'	61.4'				
C	B	(11.0m)	B	(18.7m)			B	(11.0m)			B	(18.7m)	B	(11.0m)	B	(18.7m)		
0	30.0	17,100	55.3	3,500			30.0	6,100			30.0	17,100	55.3	3,500				

A : Boom length in feet C : Loaded boom angle (deg.)
 B : Load radius in feet D : Minimum boom angle (deg.) for indicated length (no load)

NOTE: Standard number of parts of line for on rubber operation should be according to the following table.

Boom length in feet (meters)	36.1' (11)	36.1' to 87' (11 to 26.52)	Single top
Number of parts of line	6	4	1

The lifting capacity data stored in the LOAD MOMENT INDICATOR (AML-L) is based on the standard number of parts of line listed in the chart.

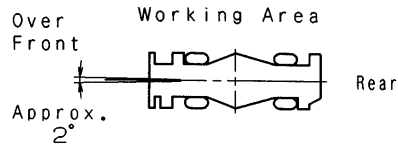

WARNING AND OPERATING INSTRUCTIONS FOR ON RUBBER LIFTING CAPACITIES

- Rated lifting capacities on rubber are in pounds and do not exceed 75 % of tipping loads as determined by SAE J765-Crane Stability Test Code.
- Rated lifting capacities shown in the chart are based on condition that crane is set on firm level surfaces with axle oscillation lockout applied. Those above bold lines are based on tire capacity and those below, on crane stability. They are based on actual load radius increased by tire deformation and boom deflection.
- If the axle oscillation lockout cylinders contain air, the axle will not be locked completely and rated lifting capacities may not be obtainable. Bleed the cylinders according to the operation safety and maintenance manual.
- Rated lifting capacities are based on proper tire inflation, capacity and condition. Damaged tires are hazardous to safe operation of crane.
- Tires shall be inflated to correct air pressure.

Tires	Air Pressure
29.5-25 22PR	60 psi (4.2 kgf/cm ²)
- Over front operation shall be performed within two degrees in front of chassis.
- On rubber lifting with "jib" is not permitted. Maximum permissible boom length is 87 ft. (26.52m).
- When making lift on rubber stationary, set parking brake.
- For creep operation, boom must be centered over front of machine, swing lock engaged, and load restrained from swinging. Travel slowly and keep the lifted load as close to the ground as possible, and especially avoid any abrupt steering, accelerating or braking.
- Do not operate the crane while carrying the load.
- Creep is motion for crane not to travel more than 200 ft. (60 m) in any 30 minute period and to travel at the speed of less than 1mph (1.6km/h).
- For creep operation, set Drive select switch to "4-WHEEL (Lo)" and set gear shift lever to "1".

WARNING AND OPERATING INSTRUCTIONS FOR USING THE LOAD MOMENT INDICATOR (AML-L)

1. When operating crane on outriggers:
 - Set P.T.O. switch to "ON".
 - Press the outrigger mode select key to register for the outrigger operation. Press the set key, then the outrigger mode indicative symbol changes from flickering to lighting.
 - Press the boom mode select key to register the boom mode, then the boom mode indicative symbol changes from lighting to flickering. Each time the boom mode select key is pressed, the mode changes. Press the set key to select the status that corresponds to the actual state of the boom, then the boom mode indicative symbol changes from flickering to lighting.
 - When erecting and stowing jib, select the status of jib set (jib state indicative symbol flicker).
2. When operating crane on rubber:
 - Set P.T.O. switch to "ON".
 - Press the outrigger mode select key. The on-tire mode indicative symbol comes on. Each time the outrigger mode select key is pressed the mode changes. Select the creep operation, the on-tire mode indicative symbol flicker.
 - Press the boom mode select key to register the boom mode.

However, pay attention to the following.

 - (1) For stationary operation.
 - The front capacities are attainable only when the over front position symbol comes on. When the boom is more than 2 degrees from centered over front of chassis, 36° capacities are in effect.
 - When a load is lifted in the front position and then swung to the side area, make sure the value of the LOAD MOMENT INDICATOR(AML-L) is below the 360o lifting capacity.
- (2) For creep operation.
 - The creep capacities are attainable only when boom is in the straight forward position of chassis and the over front position symbol is on. If boom is not in the straight forward position of chassis , never lift load.
3. A swing does not automatically stop even if the crane becomes overloaded.
4. During crane operation, make sure that the displays on front panel are in accordance with actual operating conditions.
5. The displayed values of LOAD MOMENT INDICATOR (AML-L) are based on freely suspended loads and make no allowance for such factors as the effect of wind, sudden stopping of loads, supporting surface conditions, inflation of tire, operating speed, side loads, etc.
For safe operation, it is recommended when extending and lowering boom or swinging, lifting loads shall be appropriately reduced.
6. LOAD MOMENT INDICATOR (AML-L) is intended as an aid to the operator. Under no condition should it be relied upon to replace use of capacity charts and operating instruction. Sole reliance upon LOAD MOMENT INDICATOR (AML-L) aids in place of good operating practice can cause an accident. The operator must exercise caution to assure safety.

TR-600XL- 4 Axle weight distribution chart

	Pounds			Kilograms		
	GVW	Front	Rear	GVW	Front	Rear
Base machine	92,387	48,438	43,949	41,906	21,971	19,935
Remove: 1. 6.2 ton (5.6 metric ton) hook ball	-289	-403	115	-131	-183	52
2. Top jib (25.6')	-677	-791	115	-307	-359	52
3. Base jib (32.5')	-1,832	-3,344	1,512	-831	-1,517	686
4. Auxiliary lifting sheave	-110	-311	201	-50	-141	91
5. 60 ton (54.4 metric ton) hook block	-1,049	-1,894	844	-476	-859	383
Option: 1. Hot water cab heater and air conditioner	214	68	146	97	31	66

MEMO

TADANO AMERICA CORPORATION

333 NORTH PARK CENTRAL DR, SUITE Z
HOUSTON, TEXAS 77073 U.S.A.
PHONE: (218) 869-0030 EXT.315
FAX: (218) 869-0040
<http://www.tadanoamerica.com/>

Form No. TAC-TR-600XL-04-021028